

Part Nos. 08IFE92A and 08IFE92B

Back to [Fiber Optic Devices](#) Main Page

Plastic Fiber Optic Blue LEDs

IF-E92



DESCRIPTION

The IF-E92A and IF-E92B are blue LEDs housed in a “connector-less” style plastic fiber optic package. The IF-E92A contains a Silicon Carbide die with a spectral output peaking at 430 nm and the IF-E92B die is made from Gallium Nitride peaking at 470 nm. The device package features an internal micro-lens and a precision-molded PBT housing to ensure efficient optical coupling with standard 1000 μm core plastic fiber cable.

APPLICATION HIGHLIGHTS

These LEDs are low-cost alternatives to other light sources for producing a narrowband blue light output that can be efficiently coupled into a fiber cable. They can be used in a variety of sensor and display applications that require a narrowband optical light source whose intensity can be easily adjusted or modulated without changing optical spectrum. When combined with red and green LEDs the IF-E92A and IF-E92B provide an RGB source for generating white or multicolored light. Applications include process control for color identification/separation and demonstration of wavelength division multiplexing for educational purposes. The IF-E92A and IF-E92B are also capable of digital data rates of 1 Mbps and 800 kbps respectively. The electrical drive circuit design is the same as that of other LEDs, making the IF-E92A and IF-E92B cost-effective light sources in a variety of analog, digital sensor and lighting applications.

APPLICATIONS

- Optical Sensors
- RGB Light Sources
- Color Separation for Process Control
- Medical Instruments
- Analog and Digital Data Links
- Robotics Communications
- Display Indicators
- Electronic Games
- Wavelength Multiplexing
- Fluorescent Instruments

FEATURES

- ◆ Easily Adjusted or Modulated Blue Optical Output
- ◆ Fast Transition Times
- ◆ No Optical Design Required
- ◆ Mates With Standard 1000 μm Core Jacketed Plastic Fiber Cable
- ◆ Internal Micro-Lens for Efficient Optical Coupling
- ◆ Inexpensive Plastic Connector Housing
- ◆ Connector-Less Fiber Termination

MAXIMUM RATINGS

(T_A = 25°C)

Operating and Storage Temperature Range (T _{OP} , T _{STG})-40° to 60°C
Junction Temperature (T _J)85°C
Soldering Temperature (2 mm from case bottom) (T _S) t ≤ 5 s240°C
Reverse Voltage (V _R)5 V
Power Dissipation (P _{TOT}) T _A = 25°C60 mW
De-rate Above 25°C1.1 mW/°C
Forward Current, DC (I _F)35 mA
Surge Current (I _{FSM}) t ≤ 10 μs75 mA

CHARACTERISTICS (T_A = 25°C)

Parameter	Symbol	IF-E92A	IF-E92B	Unit
Peak Wavelength	λ _{PEAK}	430	470	nm
Spectral Bandwidth (50% of I _{MAX})	Δλ	65	25	nm
Output Power Coupled into Plastic Fiber (1 mm core diameter). Distance Lens to Fiber ≤ 0.1 mm, 10 cm polished fiber, I _F = 10 mA	Φ _{min}	25 -16	75 -11	μW dBm
Switching Times (10% to 90% and 90% to 10%) (R _L = 47 Ω, I _F = 10 mA)	t _r , t _f	.5	.6	μs
Capacitance (V _F = 0, F = 1 MHz)	C ₀	100	100	pF
Forward Voltage (I _F = 20 mA)	V _f	4.5 max	4.0 max	V
Temperature Coefficient, λ _{PEAK}	TC _λ	.16	.16	nm/K

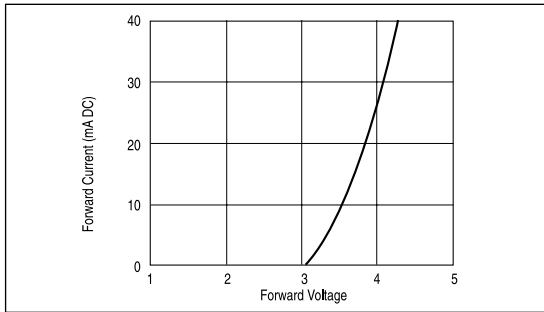

FIGURE 1. Forward current versus forward voltage.

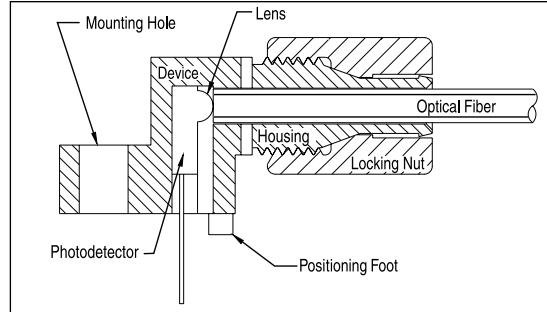

FIGURE 3. Cross-section of fiber optic device.

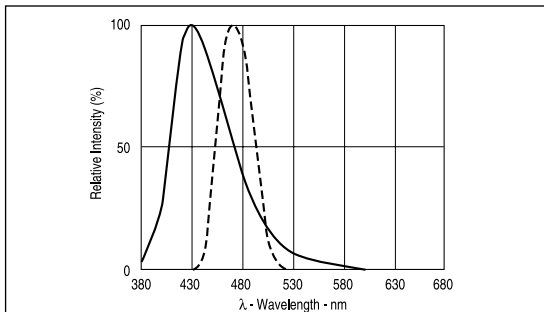

FIGURE 2. Typical spectral output vs. wavelength.

FIBER TERMINATION INSTRUCTIONS

1. Cut off the ends of the optical fiber with a single-edge razor blade or sharp knife. Try to obtain a precise 90-degree angle (square).
2. Insert the fiber through the locking nut and into the connector until the core tip seats against the internal micro-lens.
3. Screw the connector locking nut down to a snug fit, locking the fiber in place.

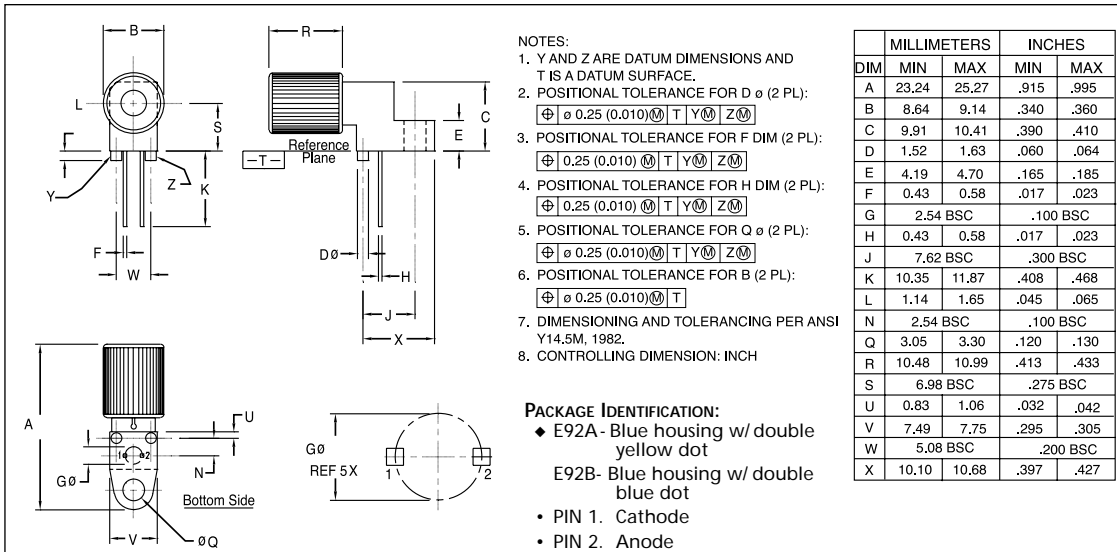

FIGURE 4. Case outline.