



LED LAMP

FYL-3019PGUYC1A

Features:

- High intensity
- General purpose leads
- RoHs complant.

Descriptions:

- Dice material Y: AlGaInP
G: InGaN
- Emitting Color R: Super bright Yellow
G: Pure green
- Device Outline: Φ 3mm Round Type.
- Lens Type: Water clear

Radiation pattern.

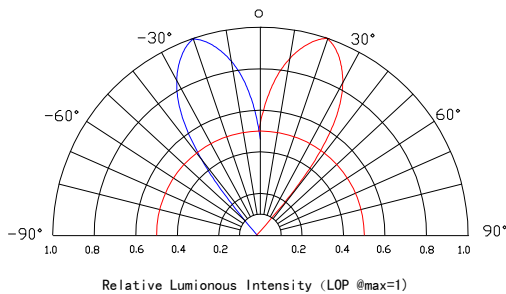

Package configuration

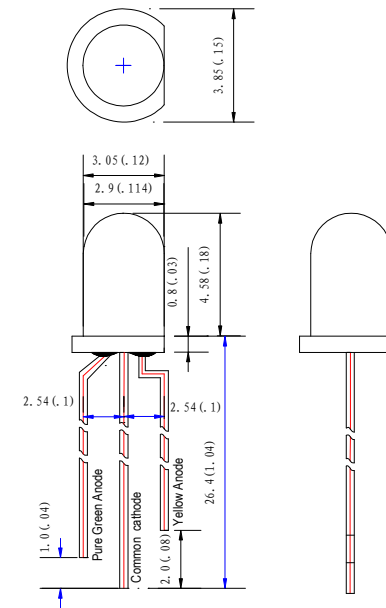

- ◆ All dimensions are millimeters (inches)
- ◆ Tolerance is $\pm 0.25\text{mm}(0.010\text{'})$ unless otherwise noted.

Absolute maximum ratings($T_a=25^\circ\text{C}$)

Parameter	MAX.		Unit
	Power Dissipation	R	
	G	50	
Peak Forward Current (1/10 Duty Cycle, 0.1ms Pulse Width)	100		mA
Continuous Forward Current	20		mA
Derating Linear From 50°C	0.4		mA/ $^\circ\text{C}$
Reverse Voltage	5		V
Electrostatic Discharge (ESD)	150		V
Operating Temperature Range	-30 $^\circ\text{C}$ to +80 $^\circ\text{C}$		
Storage Temperature Range	-40 $^\circ\text{C}$ to +100 $^\circ\text{C}$		
Lead Soldering Temperature[4mm(.157") From Body]	260 $^\circ\text{C}$ for 5 Seconds		

Electrical and optical characteristics(Ta=25 °c)

Parameter	Symbol	Min.	Typ.	Max.	Unit	Test Condition	
Luminous Intensity	I _v	Y	-	1800	-	mcd	I _F =20mA
		G	-	3500	-		
Viewing Angle	2θ _{1/2}	Y	35	40	45	Deg	I _F =20mA
		G	35	40	45		
Peak Emission Wavelength	λ _p	Y	585	590	595	nm	I _F =20mA
		G	515	520	525		
Dominant Wavelength	λ _d	Y	583	588	593	nm	I _F =20mA
		G	517	522	527		
Spectral Line Half-Width	Δλ	Y	15	20	25	nm	I _F =20mA
		G	10	15	20		
Forward Voltage	V _F	Y	1.8	2.1	2.4	V	I _F =20mA
		G	2.8	3.2	3.6		
Reverse Current	I _R		-	50	uA	V _R =5V	

Typical Electrical Characteristics Curves (25 °c Ambient Temperature Unless Otherwise Noted)

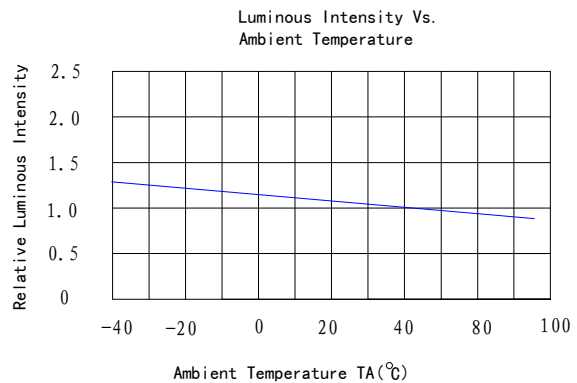
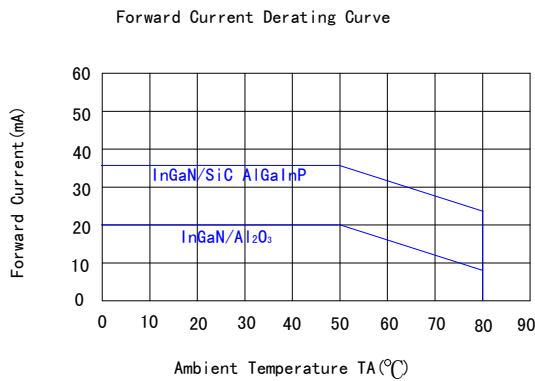
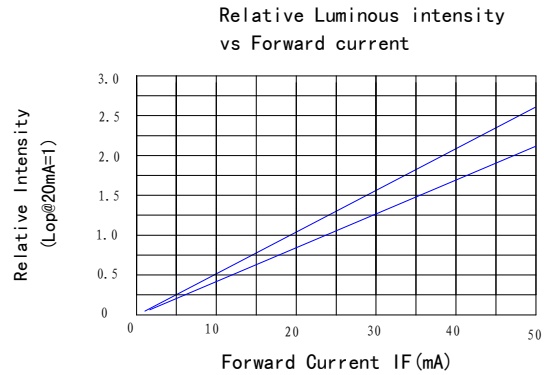
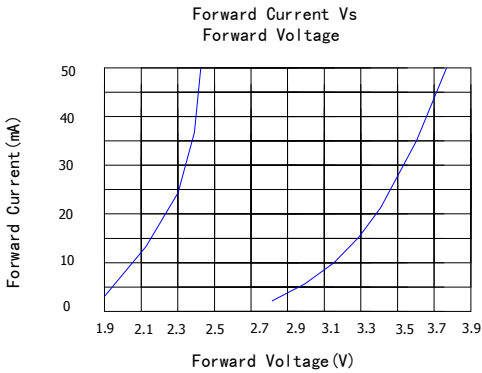
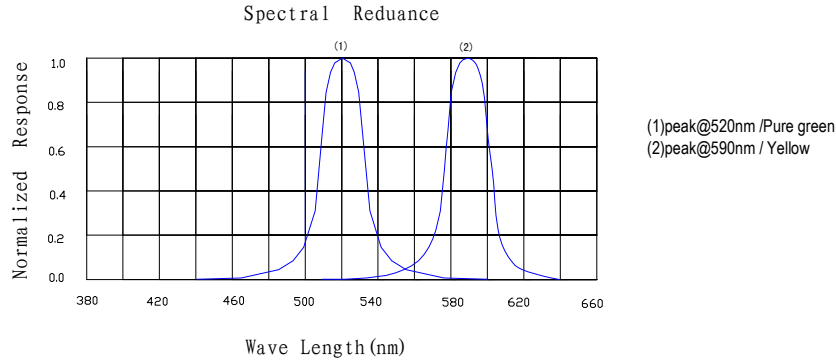

LAMP PACKING.

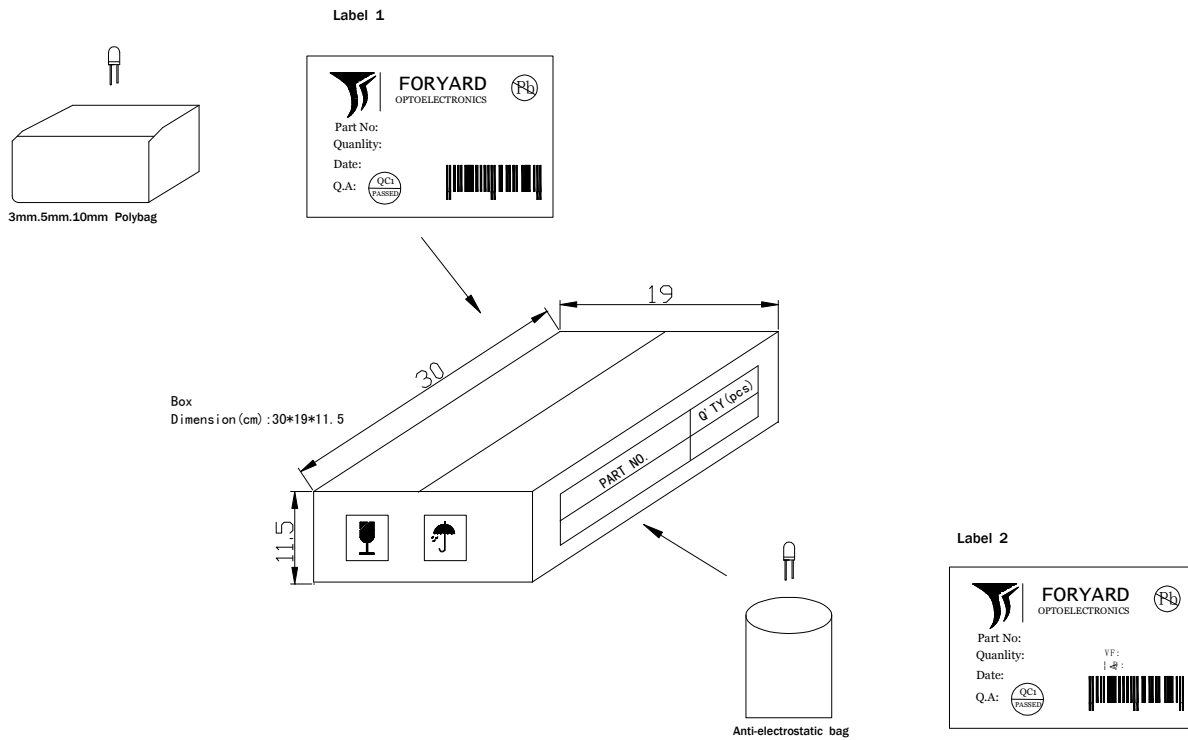

DEVICE	QTY/polybag(pcs)	Polybag/box A	Fig
5mm(T-1 3/4)	1000	8 bags	Label 1
3mm(T-1)	1000	10 bags	Label 1
10mm(T-1)	250	8 bags	Label 1
Blue/Green/White	500pcs	8 bags	Label 2

CARTON
Dimension(cm):38*31*38

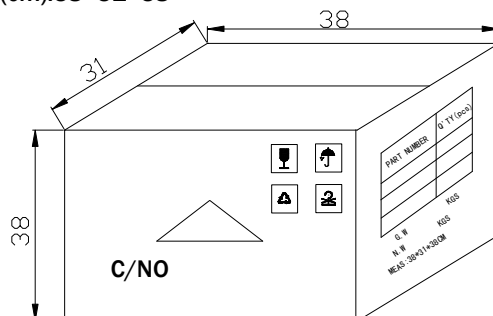

6 Boxes/Carton
5mm:48,000pcs
3mm:60,000pcs
10mm:12,000pcs
Blue/Pure Green/bluish Green
/White:24,000pcs